

Property of The Wood Shop Millwork & Joinery est. 2015

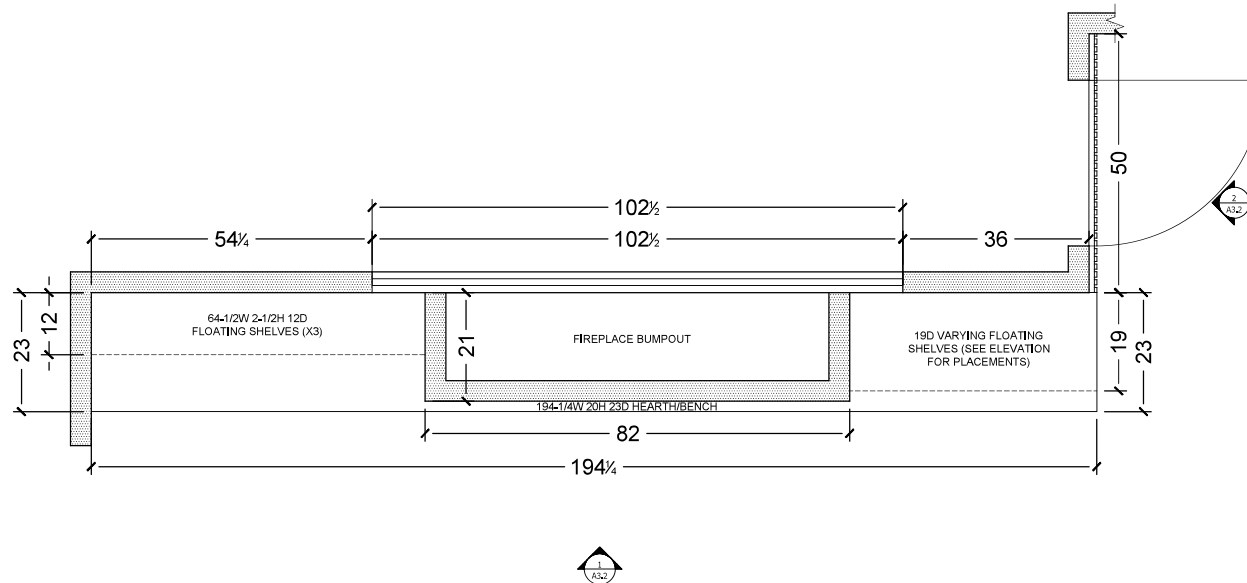

### FOYER/FIREPLACE LAYOUT

SCALE: 1/2" = 1'0"

DWG BY: S. ARDUINI

4921 Auto Rd SE  
 Salmon Arm, BC  
 V1E 1X1  
 P: 250-832-2552  
 F: 250-832-7897  
 info@thewoodshop.co



Project Name & Address

**TWS. WHITSTONE DEVELOPMENTS**  
 LECLAIR - LOT 5 BYERSVIEW  
 ARCHITECTURAL MILLWORK PLANS

**REV-D**

Customer / Contractor Initial  
 Approved For Construction

X \_\_\_\_\_

Room / Room #

**FOYER/FIREPLACE**

Drawing Notes

FINISH(S)

DOOR STYLE(S)

HARDWARE

Date

**Dec-17-2024**

Sheet

**A3.1**

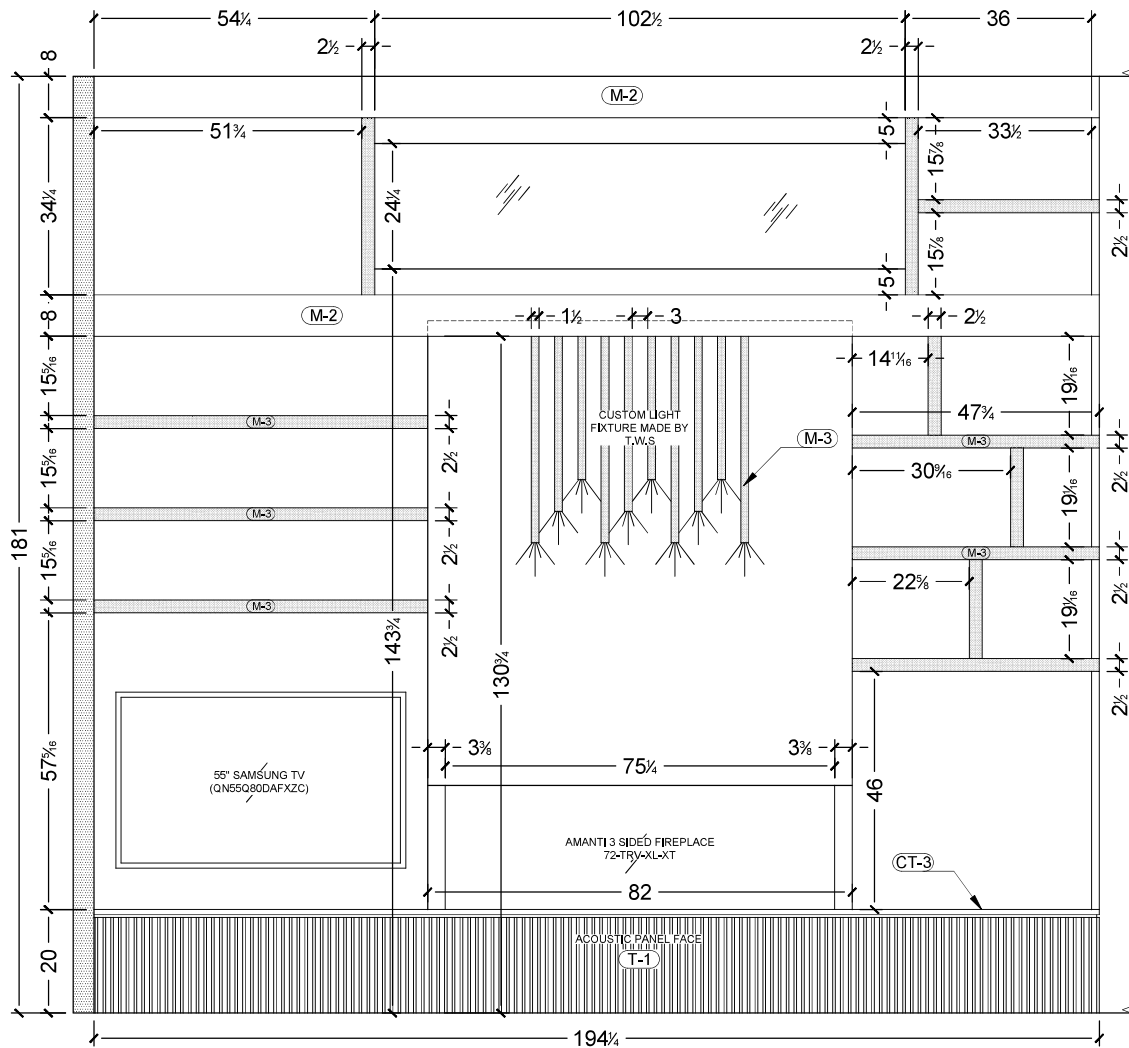

**1** FOYER/FIREPLACE ELEVATION  
SCALE: 1/2" = 1'0"

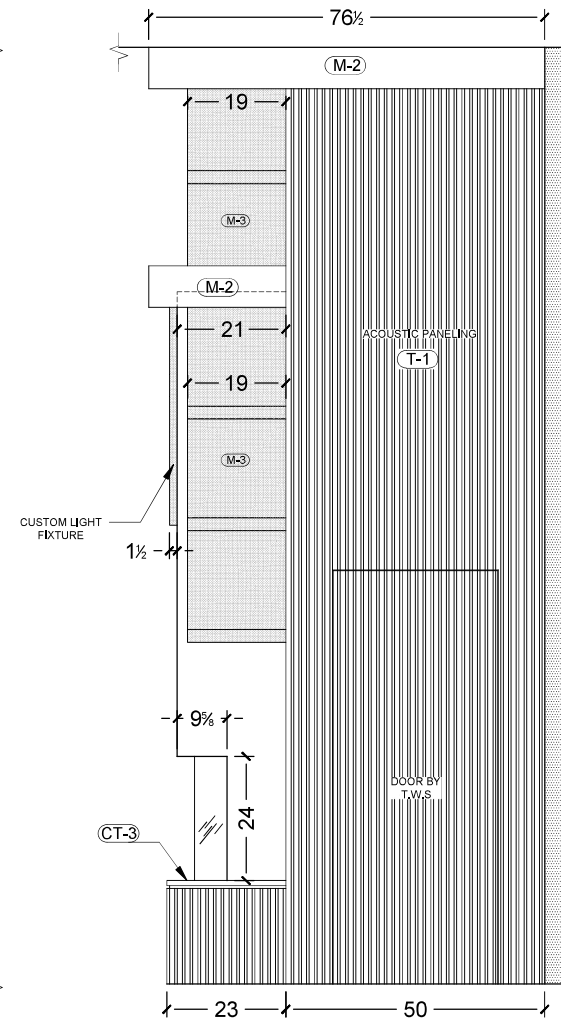

**2** FOYER/FIREPLACE ELEVATION  
SCALE: 1/2" = 1'0"

4921 Auto Rd SE  
Salmon Arm, BC  
V1E 1X1  
P: 250-832-2552  
F: 250-832-7867  
info@thewoodshop.co



Project Name & Address  
**TWS. WHITSTONE DEVELOPMENTS**  
LECLAIR - LOT 5 BYERSVIEW  
ARCHITECTURAL MILLWORK PLANS  
**REV-D**

Customer / Contractor Initial  
Approved For Construction  
x \_\_\_\_\_

Room / Room #  
**FOYER/FIREPLACE**  
Drawing Notes

FINISH(S)  
**(M-2) (M-3) (T-1)**

DOOR STYLE(S)

HARDWARE

Date  
**Dec-17-2024**

Sheet  
**A3.2**

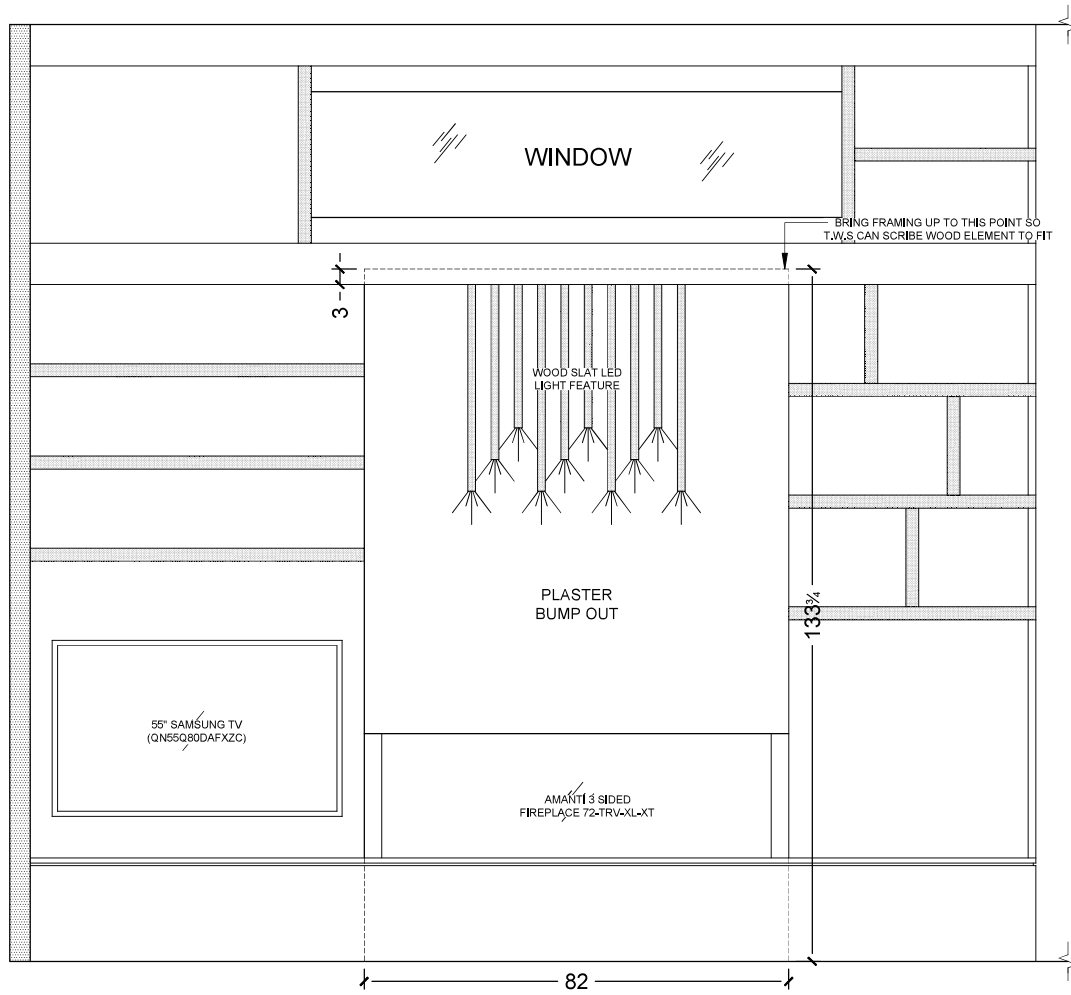

1 FOYER/FIREPLACE ELEVATION  
SCALE: 1/2" = 1'0"

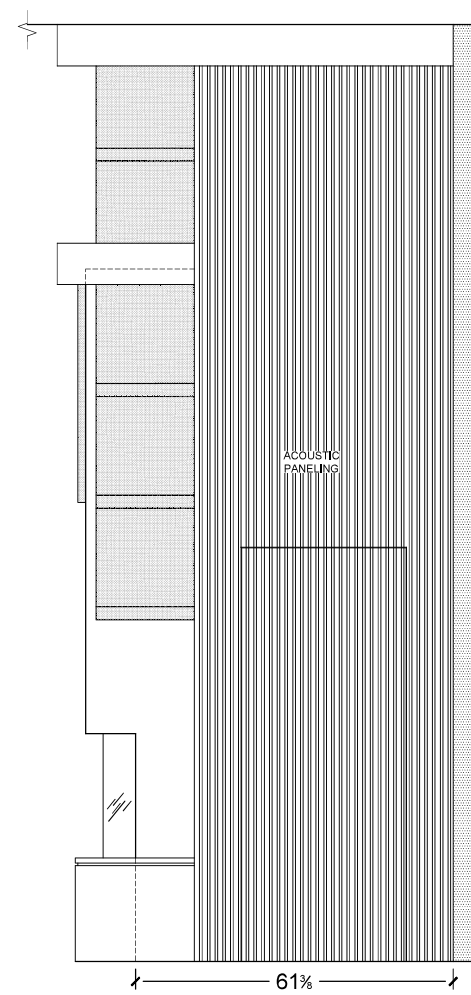

2 FOYER/FIREPLACE ELEVATION  
SCALE: 1/2" = 1'0"

4921 Auto Rd SE  
Salmon Arm, BC  
V1E 1X1  
P: 250-832-2552  
F: 250-832-7897  
info@thewoodshop.co



Project Name & Address  
**TWS. WHITSTONE DEVELOPMENTS**  
LECLAIR - LOT 5 BYERSVIEW  
ARCHITECTURAL MILLWORK PLANS

REV-D

Customer / Contractor Initial

Approved For Construction

x

Room / Room #

FOYER/FIREPLACE

Drawing Notes

FINISH(S)

DOOR STYLE(S)

HARDWARE

Date

Dec-17-2024

Sheet

A3.2A